

Ethinylestradiol (EE2) Plate, Detailed ELISA Procedure

1. Sample Pretreatment

Filter the samples if necessary and add methanol to obtain a final methanol concentration of 10% (v/v)



2. Reconstitution of Antigen-enzyme Conjugate

Reconstitute antigen-enzyme conjugate powder with 7mL of buffer solution. Mix by filling tip and expelling the contents with a pipette.

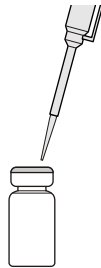

3. Addition of Standard/Sample and Conjugate

Add 100uL of EE2 standards (or sample) and 100uL of conjugate solution in each **uncoated** well of a microplate. We recommend using duplicates or triplicates. Cover the wells with parafilm or tape and mix the contents by moving the strip holder in a rapid circular motion on the benchtop for 30 seconds. Be careful not to spill contents.

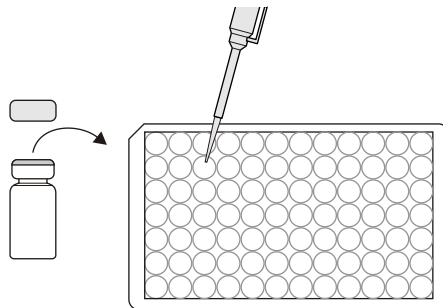

4. Incubation (Competitive Reaction)

Dispense aliquots of 100uL of the above mixture into each **antibody coated** well of a microplate. Cover the wells with parafilm or tape and mix the contents by moving the strip holder in a rapid circular motion on the benchtop for 30 seconds. Be careful not to spill contents. Incubate for 60 minutes at room temperature.

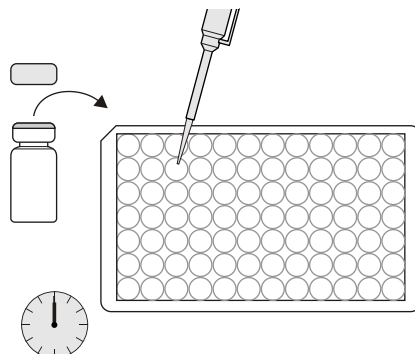

5. Washing Solution

Dilute 6-fold wash solution with 5 volumes of distilled water. Rise each microplate well with 300uL of the 1x wash solution and repeat 3 times.

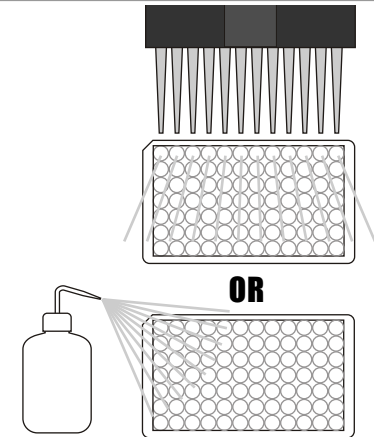

6. Addition of Color Solution

Dispense 100uL of the Color Solution into each well successively using a multi-channel pipette or a stepping pipette. Cover the wells with parafilm or tape and mix the contents by moving the strip holder in a rapid circular motion on the benchtop for 30 seconds. Be careful not to spill contents. Incubate for 30 minutes at room temperature.

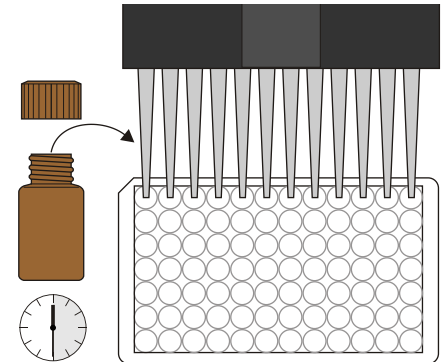

7. Addition of Stopping Solution

Add 100uL of stop solution to the wells in the same sequence as for the substrate solution using a multi-channel pipette or a stepping pipette.

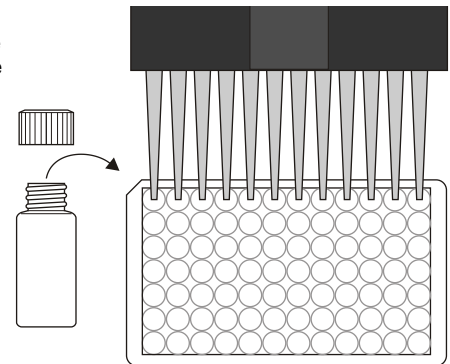

8. Quantification

Measure the absorbance at 450nm for each standard solution and generate a standard curve. Calculate the quantity of ES in a sample from the absorbance reading.

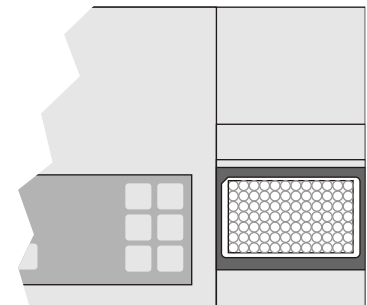

For Ordering or Technical Assistance Contact:

ABRAXIS, LLC
54 Steamwhistle Drive, Warminster, PA 18974
Phone: 215-357-3911 Fax: 215-357-5232
www.abraxiskits.com

Ethinylestradiol (EE2) Plate, Concise ELISA Procedure

1. Sample Pretreatment

Filter the samples if necessary and add methanol.



2. Reconstitution of Antigen-enzyme Conjugate

Reconstitute conjugate bottle with 7mL of buffer solution.

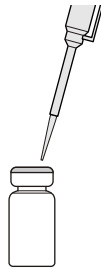

3. Addition of Standard/Sample and Conjugate

Add in duplicates 100uL of EE2 standards (or sample) and 100uL of conjugate solution to each well of an **uncoated** microplate. Swirl to mix.

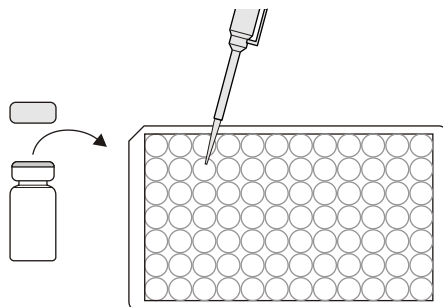

4. Incubation (Competitive Reaction)

Dispense 100uL of the above mixture into each well of an **antibody coated** microplate. Incubate for 60 minutes.

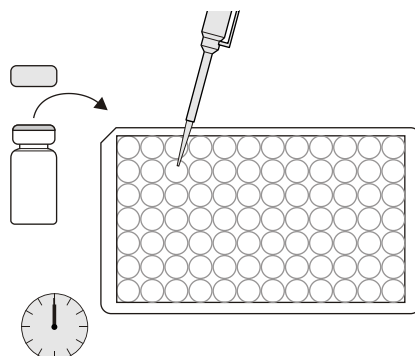

5. Washing Solution

Rise with 300uL of the 1x wash solution and repeat 3 times.

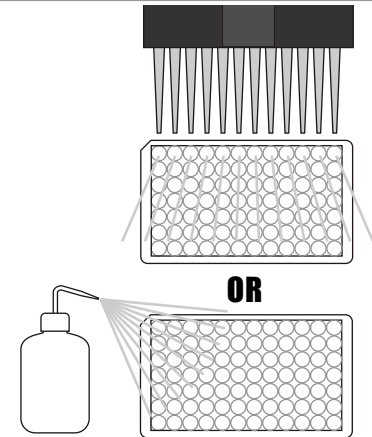

6. Addition of Color Solution

Add 100uL of the Color Solution into each well. Incubate for 30 minutes away from sunlight.

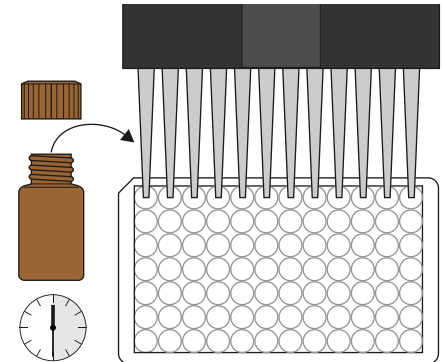

7. Addition of Stopping Solution

Add 100uL of stop solution into each well.

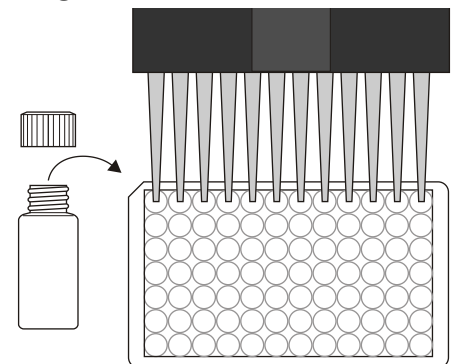

8. Quantification

Measure the absorbance at 450nm.

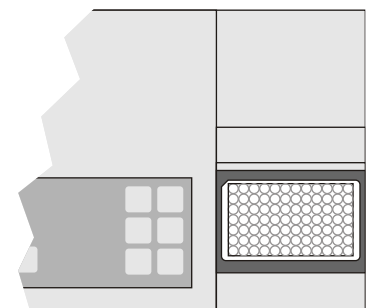

For Ordering or Technical Assistance Contact:

ABRAXIS, LLC
54 Steamwhistle Drive, Warminster, PA 18974
Phone: 215-357-3911 Fax: 215-357-5232
www.abraxiskits.com