

Glyphosate Plate, Detailed ELISA Procedure

1. Addition of Standards, Samples

Add 50 μ L of the derivatized standard solutions, control, or samples into the wells of the test strips according to the working scheme given. We recommend using duplicates or triplicates.

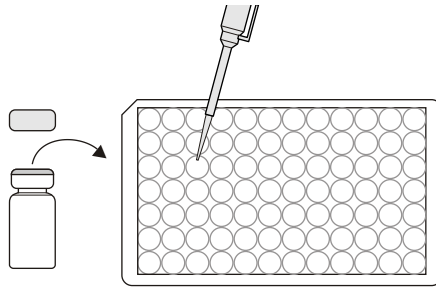

2. Addition of Antibody Solution

Add 50 μ L of the anti-Glyphosate Antibody Solution into the wells of the test strips according to the working scheme given. We recommend using duplicates or triplicates. Cover the wells with parafilm or tape and mix the contents by moving the strip holder in a rapid circular motion on the benchtop for 30 seconds. Incubate for 30 minutes.

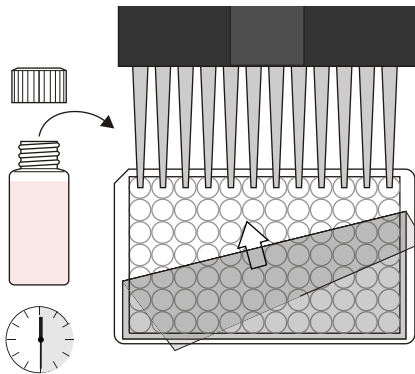

3. Addition of Enzyme Conjugate

Add 50 μ L of the enzyme conjugate to the individual wells successively using a multi-channel pipette or a stepping pipette. Cover the wells with parafilm or tape and mix the contents by moving the strip holder in a rapid circular motion on the benchtop for 30 seconds. Be careful not to spill contents. Incubate for 60 minutes at room temperature.

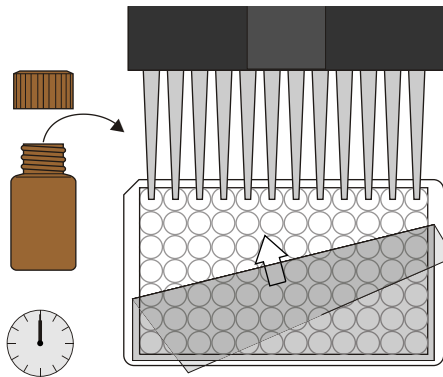

4. Washing of Plates

After incubation, remove the covering and vigorously shake the contents of the wells into a sink. Wash the strips three times with a multi-channel pipette or wash bottle using the 1X washing buffer solution. Please use at least a volume of 250 μ L of washing buffer for each well and each washing step. Remaining buffer in the wells should be removed by patting the plate dry on a stack of paper towels.

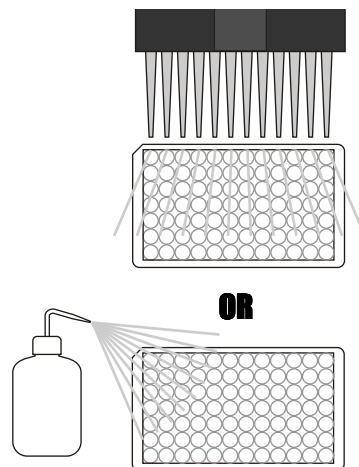

5. Addition of Substrate/Color Solution

Add 150 μ L of substrate/color solution to the individual wells successively using a multi-channel pipette or a stepping pipette. cover the wells with parafilm or tape and mix the contents by moving the strip holder in a rapid circular motion on the benchtop. Be careful not to spill contents. Incubate the strips for 20-30 minutes at room temperature.

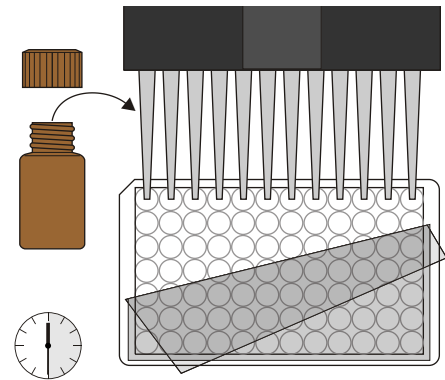

6. Addition of Stopping Solution

Add 100 μ L of stop solution to the wells in the same sequence as for the substrate multi-channel pipette or a stepping pipette.

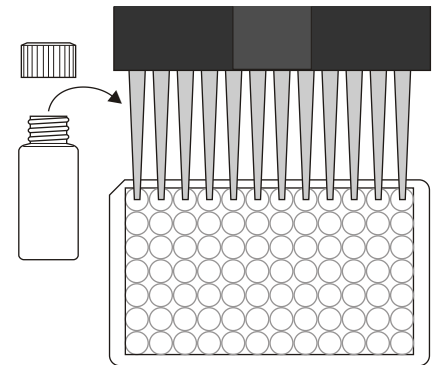

7. Measurement of Color

Read the absorbance at 450nm using a microplate ELISA reader. Calculate the results.

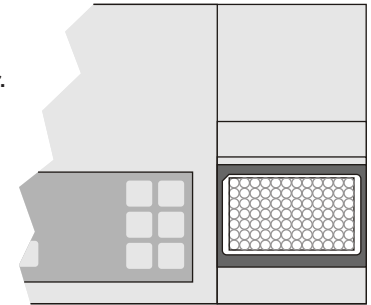

For Ordering or Technical Assistance Contact:
ABRAXIS, INC.
124 Railroad Drive, Warminster, PA 18974
Phone: 215-357-3911 Fax: 215-357-5232
www.abraxiskits.com

Glyphosate Plate Kit Part # 500086

Glyphosate Plate, Concise ELISA Procedure

1. Addition of Standards, Samples

Add 50 uL of the derivatized standard solutions, control, or samples.

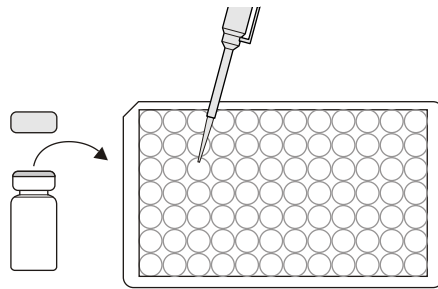

5. Addition of Substrate/Color Solution

Add 150 uL of substrate/color solution. Incubate the strips for 20-30 minutes at room temperature and away from direct sunlight.

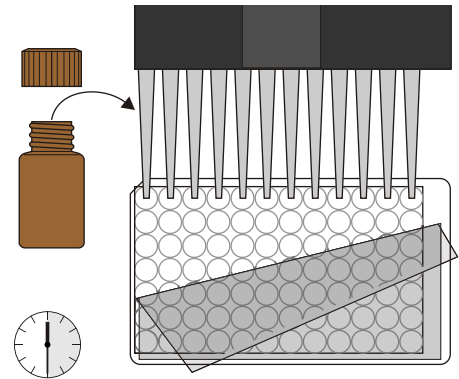

2. Addition of Antibody Solution

Add 50 uL of the anti-Glyphosate Antibody Solution. Cover and mix for 30 seconds. Incubate for 30 minutes at room temperature.

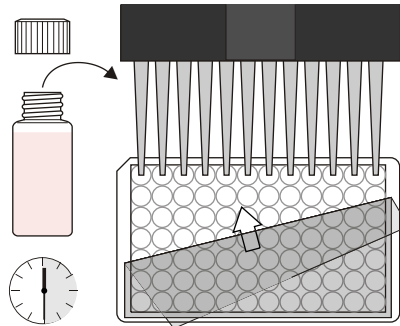

6. Addition of Stopping Solution

Add 100 uL of stop solution.

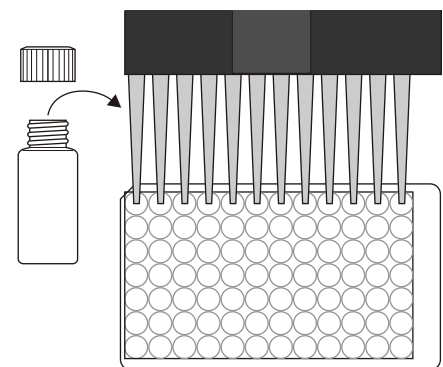

3. Addition of Enzyme Conjugate

Add 50 uL of the enzyme conjugate. Cover and mix for 30 seconds. Incubate for 60 minutes at room temperature.

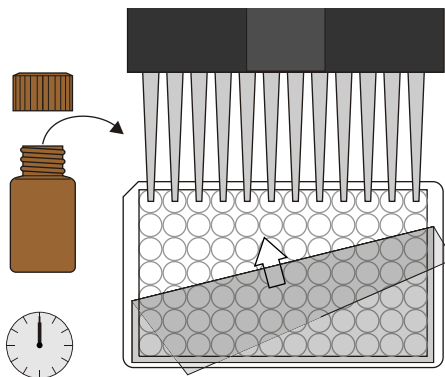

7. Measurement of Color

Read the absorbance at 450nm using a microplate ELISA reader. Calculate the results.

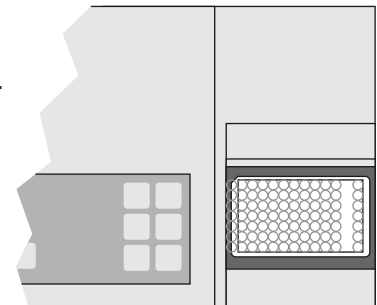

4. Washing of Plates

Wash the plates three times with 250 uL of 1X washing buffer.

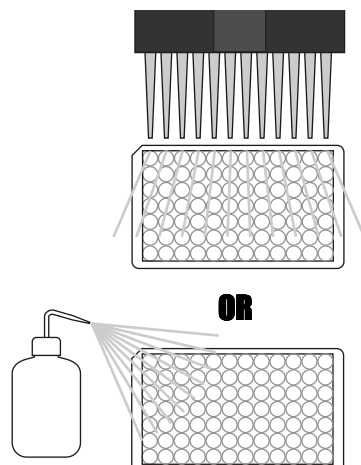

For Ordering or Technical Assistance Contact:
ABRAXIS, INC.
124 Railroad Drive, Warminster, PA 18974
Phone: 215-357-3911 Fax: 215-357-5232
www.abraxiskits.com